Pfeffingerring 201
CH-4147 Aesch
Switzerland

Phone +41-61-756 28 28
Fax +41-61-756 29 29

Collamat 2600 Technical Handbook

1	Index.....	2
2	List of Tables	4
3	List of figures	5
4	Safety advices	6
4.1	Important Warnings	6
4.2	Danger Indications	6
4.3	Symbolerklärungen	6
5	Introduction.....	8
5.1	General informations	8
5.2	The labeler C2600.....	8
5.2.1	Prevention of accidents	9
5.2.2	Noise suppression	9
5.2.3	Stability	9
5.3	Assembly parts.....	10
6	Mechanical adjustments.....	11
6.1	Traction unit.....	11
6.1.1	Threading the labelweb	11
6.2	Adjustment of rewinder coupling force	11
6.2.1	Readjustment of paper brake	12
6.2.2	Longitudinal adjustment on the module rail.....	12
6.3	Adjustment of the optical label scanner.....	13
7	Technical description.....	14
7.1	Dispenser board	14
7.1.1	Power supply	14
7.1.2	Motordriver	14
7.1.3	Controller	14
7.2	Signals and connection diagrams	15
7.2.1	Inputs.....	15
7.2.2	Outputs	16
7.3	Transformer wiring	17
7.4	Connection of the mains input.....	17
7.5	Connection of the frontpanel	18
7.6	Grounding of the labeler.....	18
7.7	Motor and motorcable	18
8	Software	20
9	Trouble shooting.....	21
9.1	Fuses.....	21
10	Peripheral units and sensors.....	22
10.1	Optical label scanner	22
10.2	Goods scanner NPN	23
10.2.1	Connecting the goods scanner.....	23
11	Cabling and setting up.....	24
11.1	Cabling	24
11.2	Setting up	24
12	Version numbers	25
13	Glossary and terms	26
13.1	Short cuts	26
13.2	Signals.....	26
13.3	Terms	26
14	Technical Data	27

14.1	Dimensions.....	27
15	Troubleshooting.....	30
15.1	Troubleshooting Collamat 2600	30
16	Revision.....	36

2

List of Tables

1	Transformer connection secondary side	17
2	Trafoanschluss Primärzeitig	17
3	Motor connection	19
4	Sicherungen	21
5	Colurs of the LSC & TCY wires	22
6	Dispenser board	25
7	Firmware	25
8	Dispencer general data (Standart values).....	28
9	Traction unit.....	28
10	Weight	28
11	Midi-unwinder	29
12	Adapter	29
13	Label scanner	29
14	Unwinder troubleshooting.....	30
15	Adapter troubleshooting	31
16	troubleshooting traction unit	32
17	troubleshooting control print	33
18	Trouble shooting checklist.....	35

3

List of Figures

1	Stability of the stand	9
2	Assembly parts	10
3	Threading	11
4	Rewinder coupling	11
5	Paperbrake	12
6	Longitudinal adjustment	12
7	Adjustment of the optical label scanner	13
8	Dispenser board	15
9	Signal inputs	16
10	TCY-current source	16
11	Mains connection	17
12	Frontpanel connection	18
13	Motor connection	19
14	Timediagram of the signals GSC, LSC and FEED	20
15	Optical label scanner	22
16	NPN-Reflective scanner	23
17	Connection of the CS IR goods scanner	23
18	Connection of a NPN-scanner	23
19	Troubleshooting	30

4 **Safety advices**

4.1 **Important Warnings**

Before installing and operating the Collamat 2600 read following safety instructions:

- The labeler C2600 is exclusively determined for labelling goods.
- The installation of a Collamat 2600 has to be done by a trained specialist. For this you have to consider the national specific regulations of
 - prevention of accidents
 - mechanical stability
 - construction of electrical and mechanical systems
 - noise suppression
- Take notice to the technical data of the Collamat 2600. Especially the environment conditions must be observed.
- The operation of the Collamat 2600 must be done by trained personnel.
- In case of non-authorized modification guarantee will fall.
- Before connecting non-standard products ask your competent technical supporter.

4.2 **Danger Indications**

- The safety symbols and danger advices on the Collamat 2600 and in this manual must strictly be observed.
- Before connecting or disconnecting the labeler to or from the main, it must be switched off.
- The labeler C2600 may only be opened by authorized personnel.
- Before opening the labeler C2600, it must be separated from the main power.
- It exists danger of pinching hairs, jewelry, ties, clothes etc. into the traction unit
- It exists danger of injury by cutting fingers in the area of the paper web.
- It exists danger of injury in the area of the dancer of the unwinder of the Collamat 2600.
- It exists danger of injury in the area of the paper stockcontroller of the Collamat 2600.
- For operation on the Collamat 2600 the operating personnel must keep to a safely place to prevent injury from the products being labeled.

4.3 **Symbolerklärungen**



ATTENTION

Indicates danger of damaging the Collamat 2600 or other system components, with a potential consequential danger of injuries.

DANGER

Indicates an immediate hazard for persons.



DANGER

Shock hazard due to high voltage at component.



DANGER

Hazard due to high temperature component.



ATTENTION

ESD warning (Electro Static Discharge). The PC boards or component may only be touched in an electrostatically protected environment.

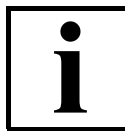

NOTE

Important or additional information to Collamat 2600 or to the documentation.

5 ***Introduction***

5.1 ***General informations***

This technical handbook describes the construction and the function of the Collamat 2600. In addition to the operating instructions, it contains the necessary tips and adjustments to get optimum use of the Collamat 2600. The descriptions of each electrical or mechanical device also helps for quick error analysis and error elimination.

We recommend you to replace the complete electronic boards. Return it to Collamat Stralfors AG or to its representative for repair. You can then feel sure, that the high quality standard of the Collamat 2600 can also be guaranteed after repair.

5.2 ***The labeler C2600***

Special characteristics of the Collamat 2600:

- resistant to wear, no clutch/brake-system
- robust, stable
- easy installation and operation due to the modular construction
- quick change-over to other labelling tasks
- high performance
- high reliability
- latest SMD-technology
- high precision 2-phase steppermotor

The traction unit as well as the other peripheral assemblies are mounted on a modular rail. The modular rail is equipped with an integrated scale.

The operating elements for dispensing speed, predispensing, optical label scanner, as well as the mains switch are placed right on the body of the traction unit itself. The feedroller of the traction unit is provided with a special coating for permanent nonslip torque transmission onto the paperweb. The rewinding force of the rewinder as well as the braking power of the paper brake are adjustable at the traction unit from the outside.

The installation of the Collamat 2600 must be done by trained personnel. For this you have to consider the national specific regulations of:

- prevention of accidents
- noise suppression
- mechanical stability
- construction of electrical and mechanical systems

5.2.1 ***Prevention of accidents***

While installing and connecting the Collamat 2600 take care that the signal cables and power cables can't become obstacles. The cables must be placed and installed according to the national safety requirements. Take care that the signal cables are not placed beneath power cables.

The power switch and the control elements must easily be accessible.

5.2.2 ***Noise suppression***

The dispenser C2600 is shielded according to the CE directives. Only cables which are certificated by Collamat Stralfors AG may be used for connecting the dispenser to the peripheral units and the mains power.

5.2.3 ***Stability***

If the Collamat 2600 is used on a movable stand, this stand must be capable to be tilt 10° in each direction. See also following Figure 1:

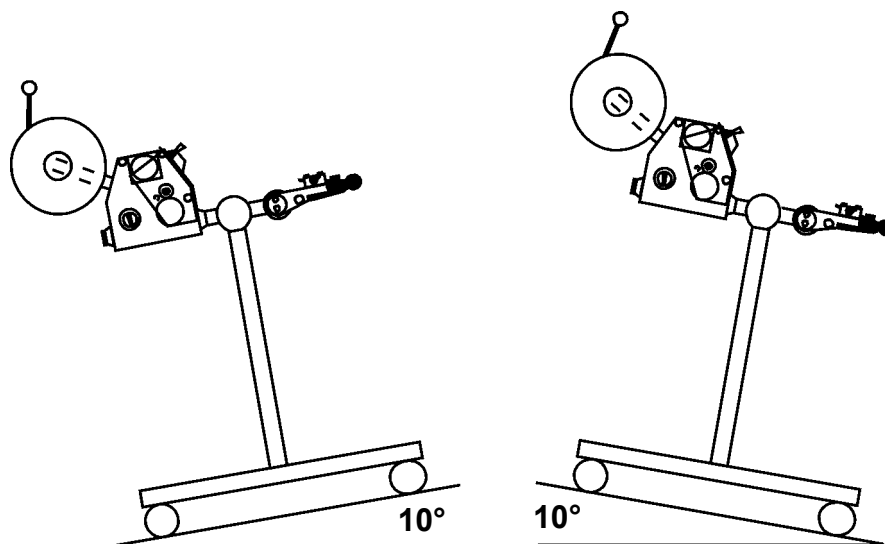

Figure 1: Stability of the stand

5.3 **Assembly parts**

The assembly parts are mounted and placed on a modular rail. Following figure 2 shows these assembly parts with their names on the modular rail:

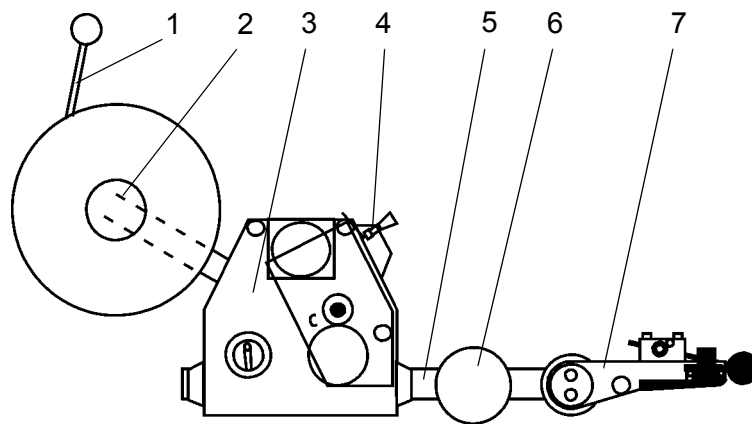

Figure 2: Assembly parts

Legend:

- 1: Unwinder dancer
- 2: Unwinder
- 3: Traction unit
- 4: Papierbremse
- 5: Modular rail
- 6: Support
- 7: Adapter

6 **Mechanical adjustments**

6.1 **Traction unit**

6.1.1 **Threading the labelweb**

Thread the labelweb as shown in figure 3 up to the dispensing edge and draw it out by approx. 1 m. Detach the labels from the paperweb at the drawn-out web. Then open the pinchroller by turning the knob (1), place the paperweb over the dispensing edge and finish threading the paperweb as shown in figure 3. Close the pinchroller. Adjust the side guides of the paperweb well, leaving 0.5 mm free space to the paperweb's edge.

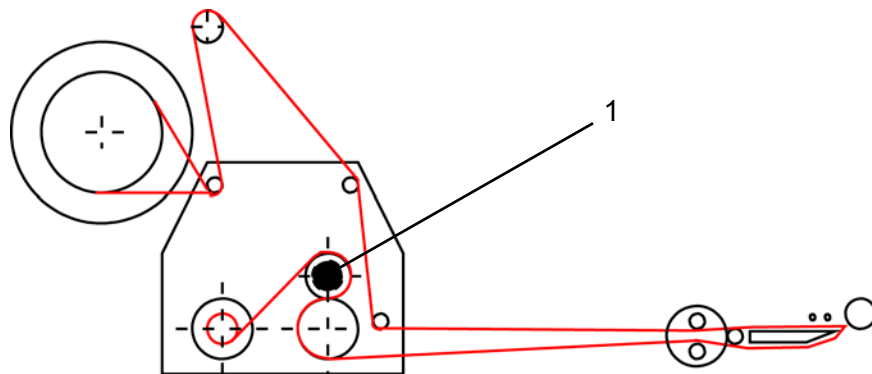

Figure 3: Threading

6.2 **Adjustment of rewinder coupling force**

The coupling force of the rewinder is factory-set. Proceed as follows if out of adjustment: Detach winding spindle (1) after unscrewing the M5-bolt (3). Screw M8-bolt (2) accordingly:

- in = harder coupling
- out = softer coupling

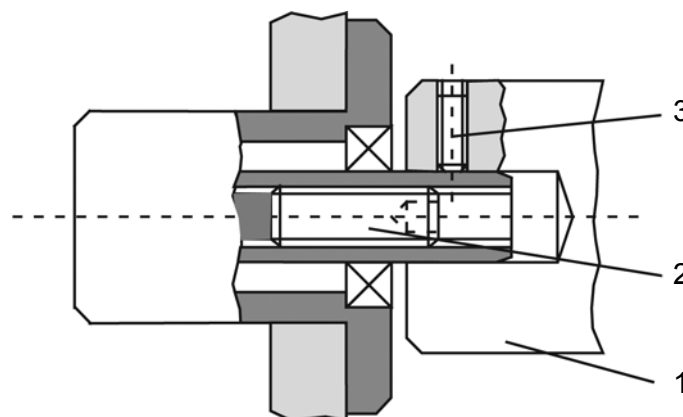

Figure 4: Rewinder coupling

6.2.1 Readjustment of paper brake

The braking force is factory-set to an optimum value. Should it, however, be unadjusted, readjust it with the M3-bolt (1) in the web-end controlbox of the traction unit, from the outside.

- Screw in bolt = higher braking force
- Unscrew bolt = lower braking force

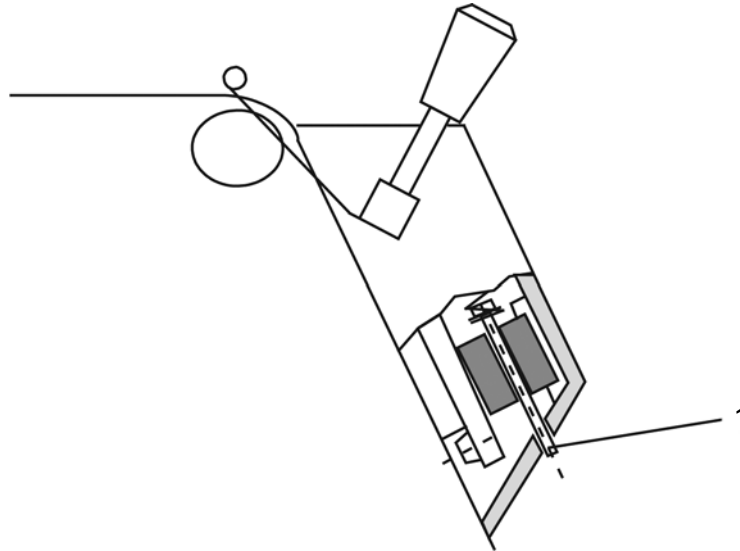

Figure 5: Paperbrake

6.2.2 Longitudinal adjustment on the module rail

Unscrew 4 bolts with special tool (wrench for socket head cap screws 5 mm) one half turn.

Move device, observing scale on module rail. Then tighten bolts equally..

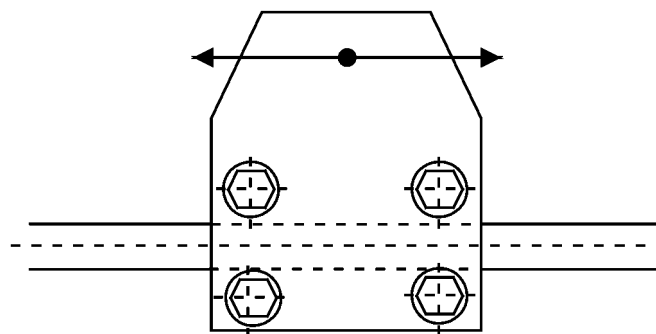

Figure 6: Longitudinal adjustment

6.3 Adjustment of the optical label scanner

Proceeding of the adjustment of the optical label scanner:

Switch on the Collamat 2600. Set the label scanner potentiometer to zero. Pull the labelweb so that the gap is located below the marking 1 of the scanner. Turn the potentiometer until the red LED on the scanner goes off. Continue pulling the labelweb until a label is located below the scanner. Continue turning the potentiometer until the LED switches off again.

The optimum setting is at the center position of the two potentiometer settings witch turned the LED off.

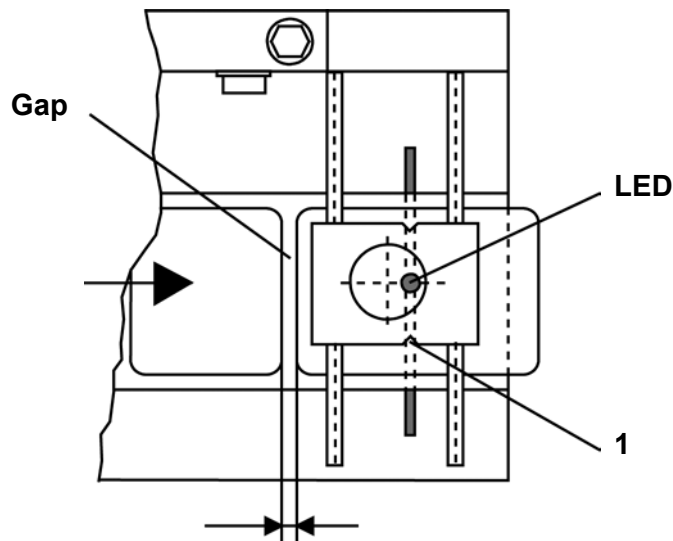

Figure 7: Adjustment of the optical label scanner

Remark:

If the setting of the optical label scanner is faulty, the gap between the labels will not be detected. After the triggering of a labelling operation, the labeler will stop after approx. 0.75 m of the labelweb. For transparent labels, please use the mechanical label scanner.

7 ***Technical description***

7.1 ***Dispenser board***

All the electronic devices including power transformer, except of the main switch with indicator lamp, are located on a printed board. The dimensions of the board are approximately 215 x 234 mm. Figure 8 shows the board with all the connectors and terminals.

The description is divided into power supply, motordriver, controller and firmware.

7.1.1 ***Power supply***

The power supply unit generates the two regulated voltages +12 V/1A and +5 V/0.5A for the logic, as well as an unregulated DC voltage of approx. 32 V/3.5 A for the stepper motor. The 5V stabilization is done by linear voltage regulators. The 12V is stabilized by a switched mode regulator.

7.1.2 ***Motordriver***

The driver board consists of 2 H-bridge circuits to drive the two motor phases. The phase current is 3 A while running, and 0.7 A when stopped. To control the current, a chopper circuit with 23 kHz chopper-frequency is used.

Dependent on the dispensing speed the processor generates a sinusoidal current.



In the case of overheating, short-circuit or malfunction the motordriver is switched off. In this case the labeler must be switched off and on again. If overheated wait until the labeler is cooled down to ambient temperature. After a short circuit replace the appropriate fuses.

7.1.3 ***Controller***

A single chip micro-controller manages the functions of the labelling process.

- All the inputs are pulled up to +12V with 2.2 K and are equipped with a low-pass filter.
- The potentiometers for speed and predispensing are scanned immediately before performing a labeling cycle.
- The control current of the label scanner is generated by a current source controlled by the third potentiometer.

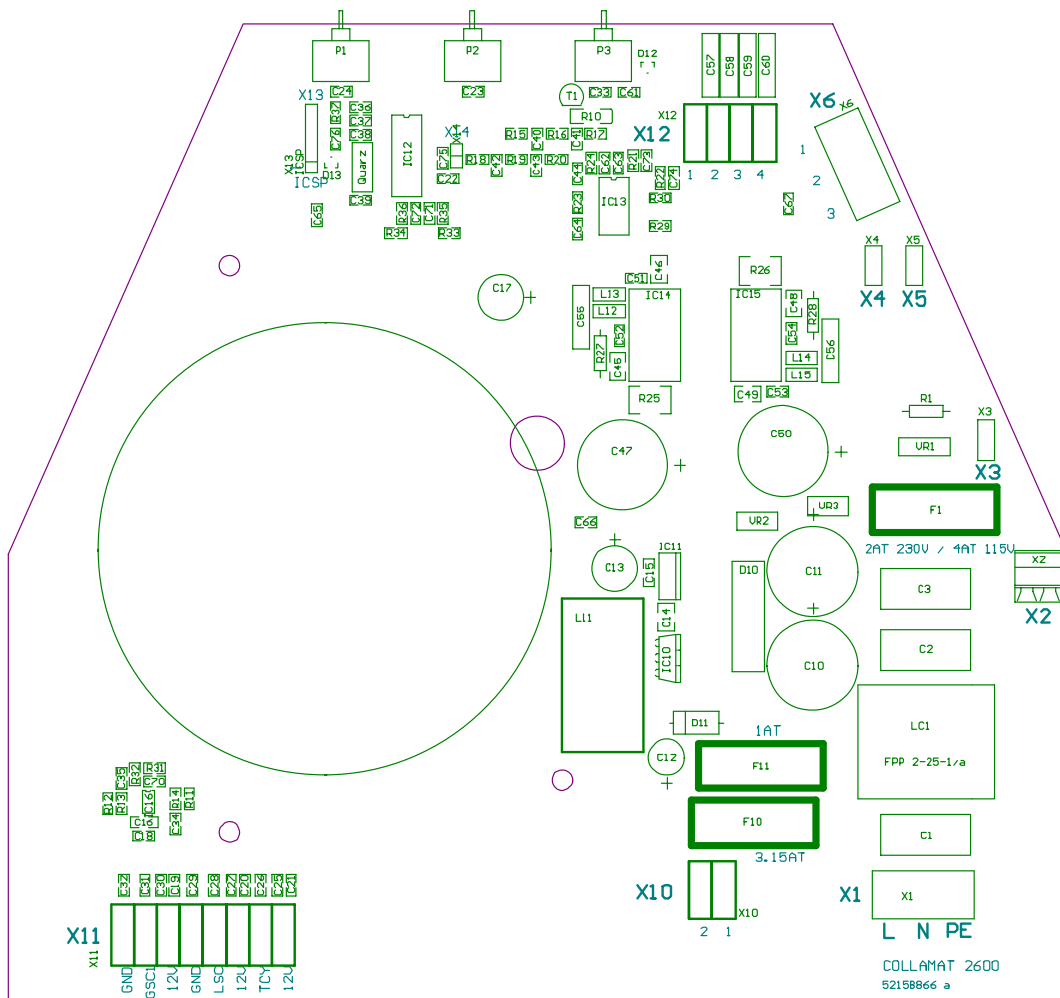

Figure 8: Dispenser board

7.2 Signals and connection diagrams

All in- and outputs are equipped with filter elements to prevent electromagnetic interference. These components also prevent interference caused by electrostatic discharge. The interference can lead to malfunction of the Collamat 2600. Anyway, installing the Collamat 2600 you have to consider the rules concerning RMI and ESD to prevent these interferences. See also chapter Cabling.

7.2.1 Inputs

The inputs are used to connect peripheral units and sensors. The inputs are activated while they are pulled to GND (0 Volt). The peripheral units from Collamat Straffors AG have NPN-outputs to 0 Volt. Figure 9 shows the schematic diagram of the inputs:

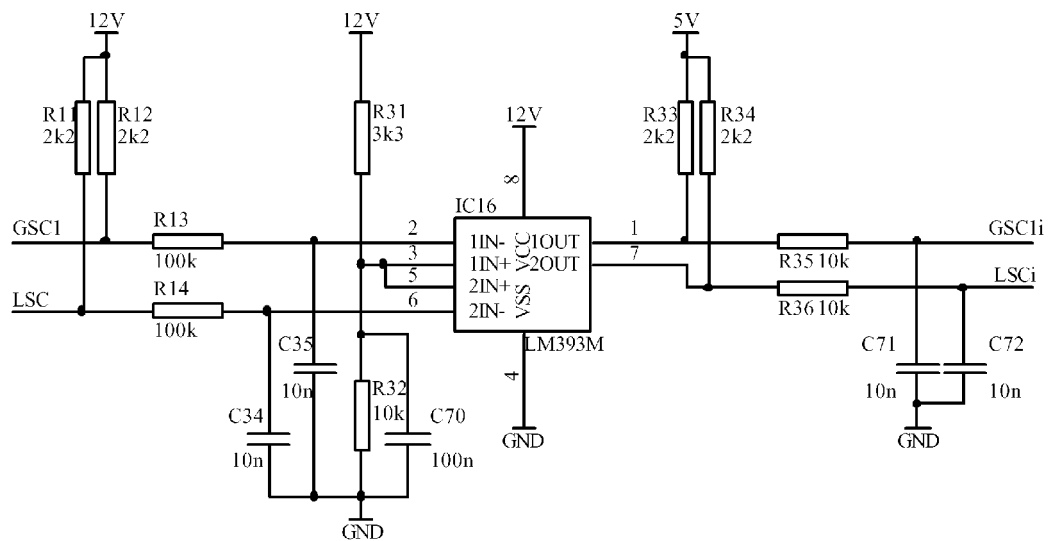

Figure 9: Signal inputs

On: $>4\text{mA}$ (or $< 2\text{ V}$)

Off: 0mA (or $> 8\text{ V}$)

V_{max} : 24 V

An input is then active, when a current of minimum 2mA is pulled to GND. The following inputs are available:

- GSC1 Goods Scanner
- LSC Label Scanner

7.2.2 Outputs

The Collamat 2600 has a current source output for the IR-transmitter of the labelscanner. Figure 10 shows the schematic diagram of the currentsource.

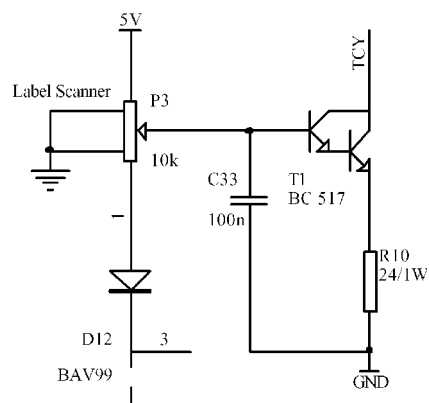

Figure 10: TCY-current source

7.3 Transformer wiring

ATTENTION:

Before opening the Collamat 2600 it must be completely disconnected from mains.

The secondary side of the transformer is connected to the terminals X10 according to the table below:

Table 1: Transformer connection secondary side

Terminal	Colour
X10.1	Green
X10.2	Red

The primary side of the transformer is connected to the terminals X6 according to the table below:

Table 2: Trafoanschluss Primärzeitig

Terminal	Colour for 220V	Colour for 110V
X6.1	Orange	Orange + Brown
X6.2	Red + Brown	nc
X6.3	Black	Red + Black

7.4 Connection of the mains input

ATTENTION:

High voltage. Mains voltage

The powercord must be connected to the terminal X1. To prevent interferences it must be looped through a ferrite-filter as shown in Figure 10:

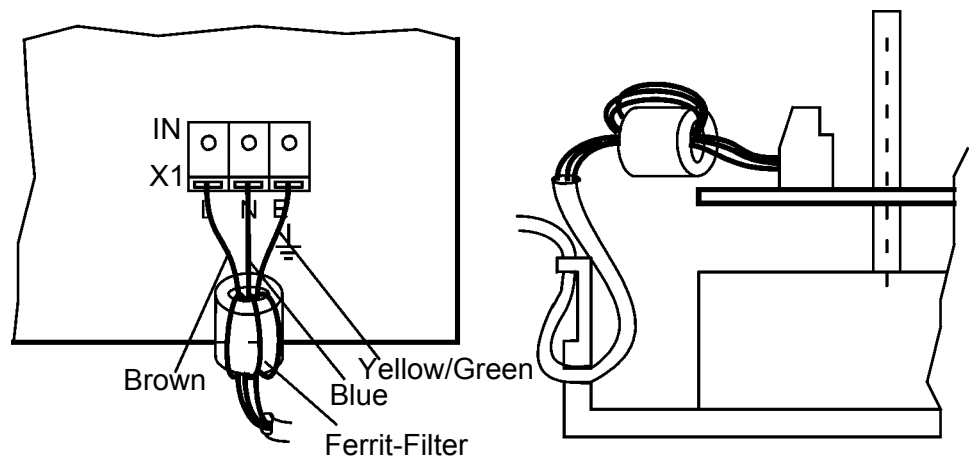

Figure 11: Mains connection

7.5 Connection of the frontpanel

The frontpanel must be connected as shown in Figure 12:

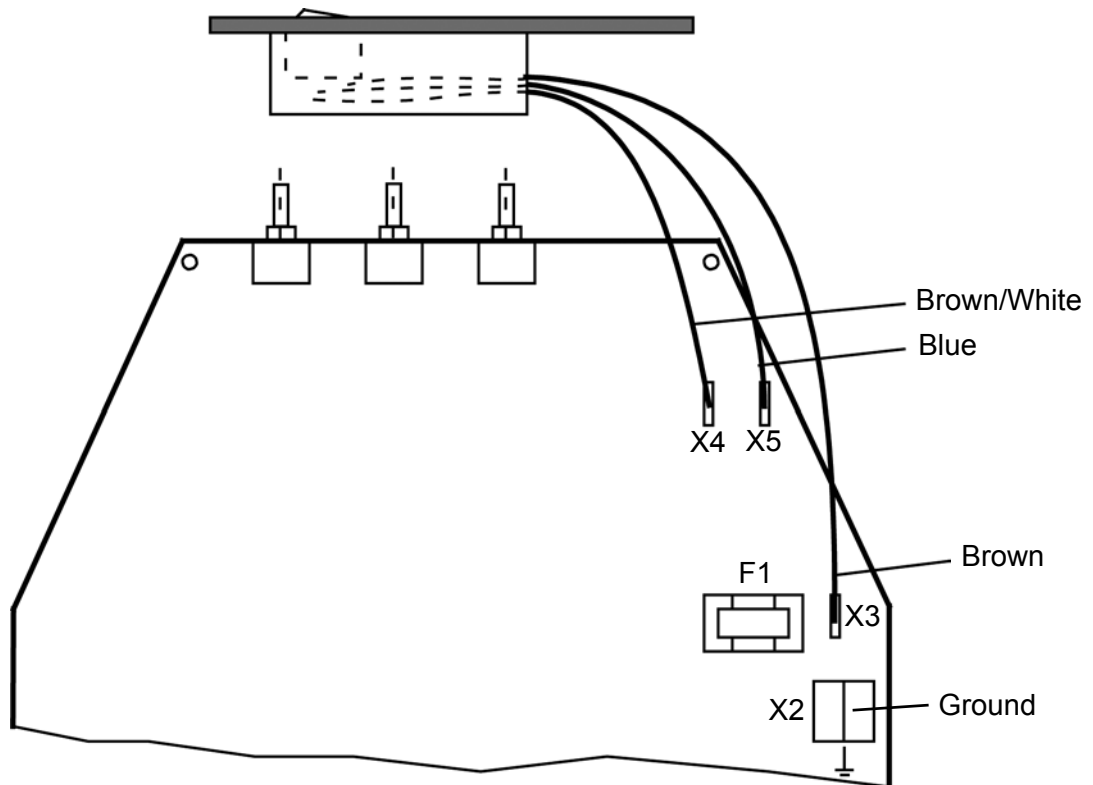

Figure 12: Frontpanel connection

7.6 Grounding of the labeler



The grounding of the module rail and of the adapter must be done to terminal X2. See also Figure 12.

7.7 Motor and motorcable

Attention:



- **The motor never must be dismantled !**
- **Steppermotor heats up during operation !**
- **When connecting or disconnecting the motor, the labeler must be switched off !**
- **While working on the motor, the labeler must be disconnected from mains !**

The motor is connected inside of the labeler. The motor cable is lead through the hole in the middle part of the board. See Figure 13:

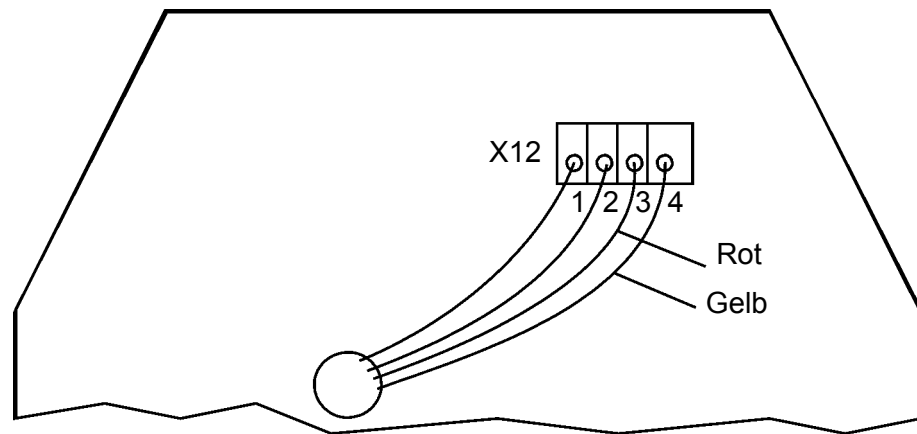

Figure 13: Motor connection

The motorwires are connected to the terminal X12. The mode connecting the orange and black wire determines the turning direction of the stepping motor. See also table below:

Table 3: Motor connection

Terminal	Left	Right
X12.1	black	orange
X12.2	orange	black
X12.3	red	red
X12.4	yellow	yellow

After turning on the labeler, the input signals are scanned to start a labeling cycle.

The dispensing of a label is triggered by the negative edge of GSC (Goods scanner input). The stop of the labelling is triggered by the detection of the gap (LSC) and performing the remaining steps for the predispensing.

The timing diagram of the signals is shown in Figure 14:

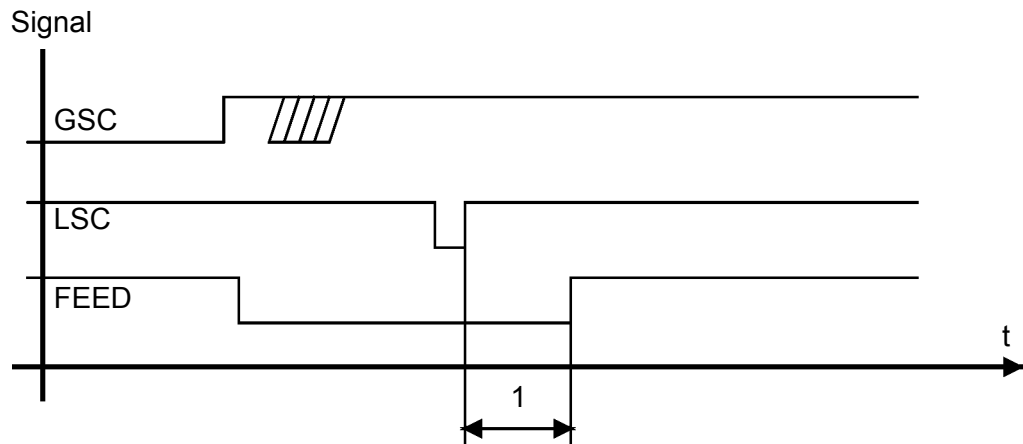

Figure 14: Timediagram of the signals GSC, LSC and FEED

1. Length of the predispensing

If the signal FEED is active the motor is turning. The FEED signal has no electrical tabs on the Collamat 2600 terminals.

If the predispensing is increased, it is executed immediately. If it is reduced, it is executed after dispensing the next label.

To generate the holding torque, the motor is powered all the time.

If, for any reason, no negative edge is detected on the LSC-input, the label-web is automatically stopped after approximately 0.75 meters.

The stepper motor is driven by a sinusoidal current figure.

The minimum speed is 3 m/min. The maximum speed is 15 m/min.

9 ***Trouble shooting***

9.1 ***Fuses***

The Collamat 2600 contains three fuses:

Table 4: Sicherungen

Fuse	Voltage	Value	Part. No.
F1 110V: 230V:	Mains voltage	4AT; 5*20mm 2AT; 5*20mm	74030800 74030341
F10	Motordriver	3.15T; 5*20mm	74031216
F11	Logic 12 V, 5V	1AT; 5*20mm	74030755

To exchange the fuses, the cover of the Collamat 2600 must be removed. If the fuse of the main voltage is blown, the indicator lamp of the power switch is not illuminated when the Collamat 2600 is switched on.

ATTENTION:

If the dispenser board is defective, it must be exchanged. Any repairs or modifications not made by Collamat Stralfors AG will expire the guarantee.

10 Peripheral units and sensors

10.1 Optical label scanner

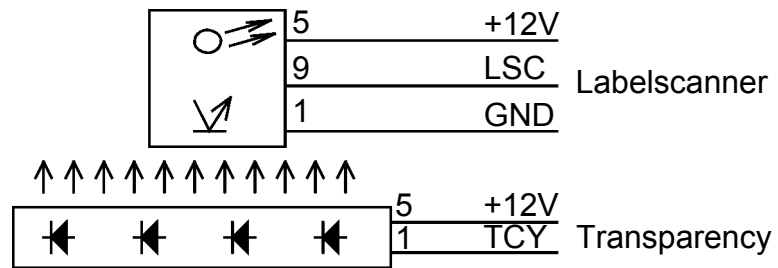

Figure 15: Optical label scanner

The colours are assigned as follows:

Table 5: Colours of the LSC & TCY wires



Signal	Colour
+12V (LSC)	green
LSC	white
GND	brown
+12V (TCY)	green
TCY	brown

10.2 Goods scanner NPN

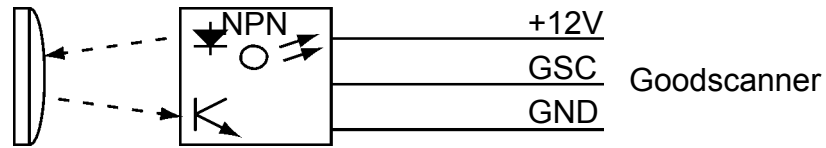

Figure 16: NPN-Reflective scanner

10.2.1 Connecting the goods scanner

The goods scanner is connected to the GSC1 connector. Figure 17 shows the connection of the standard Collamat Stralfors AG IR goods scanner:

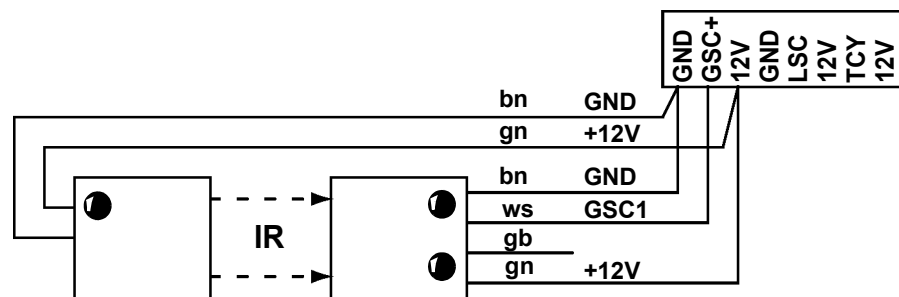

Figure 17: Connection of the CS IR goods scanner

Figure 18 shows the connection of a NPN-scanner:

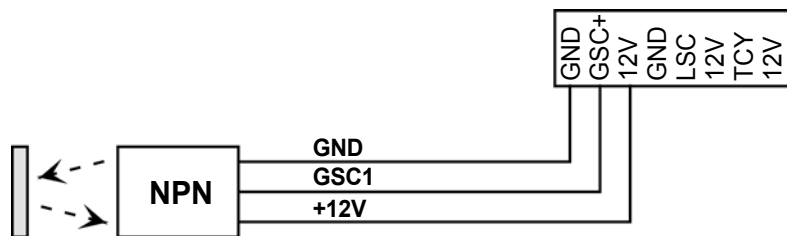

Figure 18: Connection of a NPN-scanner

11 **Cabling and setting up**

For a trouble free operation of the Collamat 2600 following items must be observed:

- Trained personnel
- Ambient temperature
- Absence of dirt and dust
- Absence of splashing water
- Installation and setting up of the installation
- Installation and setting up of the Collamat 2600
- Electromagnetic interferences
- Safety regulations and safety requirements

11.1 **Cabling**

Electromagnetic interferences can lead to non repeatable and not obvious errors while labelling. Most times misplaced layout of the cabling, RMI and ESD interferences disturb the labelling. Because of this, the following rules must be observed for the cabling:

- Separated mains and signal cables
- Use shielded cables
- All units must be grounded
- Connect only devices which meet the RMI standards
- Use power filters in interfered environments and interfered mains supplies

11.2 **Setting up**

The setting up must be done carefully by trained personnel. The following items must be observed:

- Visual check of the labeler unit
Are all electrical and mechanical units correctly attached ?
Are all connectors accessible ?
- Connect the labeler to the mains and switch it on
Is the power switch illuminated ?
- Turn off the labeler and unplug it
- Attach the goods scanner signals to the labeler
- Connect the remaining units to the labeler
- Connect the labeler to the mains and switch it on
Do the peripheral units work OK ?
- Thread the paperweb and adjust the label scanner
- Dispense a label. Is it dispensed correctly ?

12 **Version numbers**

Table 6: Dispenser board

Artikenummer	Version
5215.8866	Basic version from first series

Table 7: Firmware

Version	Datum	Eigenschaften/Änderungen
1.00	28.06.2004	Basic version from first series

13 **Glossary and terms**

13.1 **Short cuts**

ESD	ElectroStatic Discharge
EMV	ElektroMagnetische Verträglichkeit
GND	GrouND
IR	Infra Red
LED	Light Emitting Diode
nc	not connected

13.2 **Signals**

GND	GrouND Masse
GSC	Goods SCanner, Warengutabtastung
LSC	Label SCanner, Etikettenabtastung
TCY	TransparenCY, Stromsignal zur Sendediode der Etikettenabtastung

13.3 **Terms**

Stopping accuracy: Accuracy of the paper transportation

Unwinder: Device that carries the full paperweb rolls and unwinds it

Adapter: Part of the labeler by which the label is peeled off from the paperweb and applied onto the products

Rewinder: Device that takes the empty paperweb from the traction unit and rewinds it

CE-Mark: Certification for the European market, means: Conformité Européenne

Collamat: Brand name for a labeler built by Collamat Stralfors AG

GSC: Goods SCanner

LSC: Label scanner

Predispensing: Predispensing of a label on the peeling plate

Motorstep: Travelling way of the label for one motorstep

Dispensing speed: The speed of the goods to which the labels are stucked

Traction Unit: Part of the dispenser with drive unit and electronic control

14 Technical Data

14.1 Dimensions

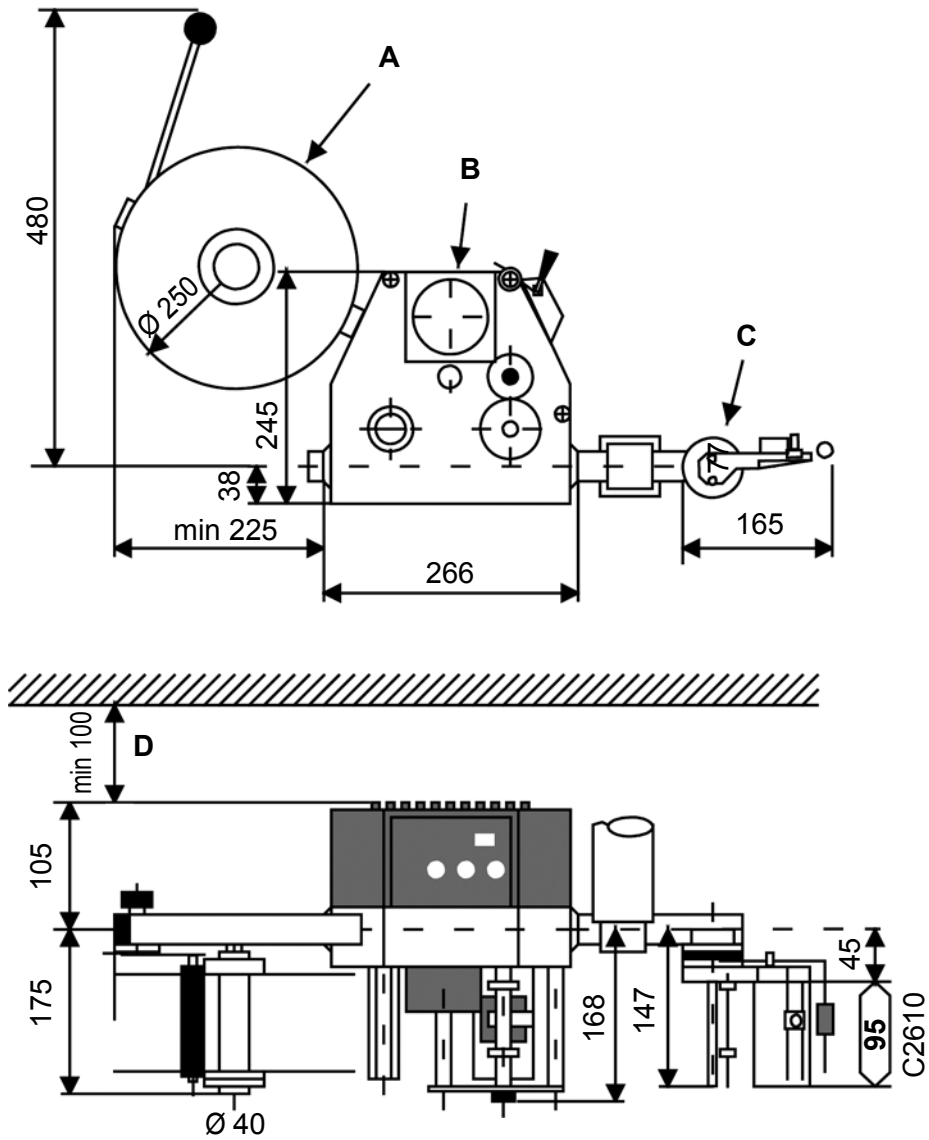

- A: Unwinder
- B: Traction unit
- C: Adapter
- D: For lid dismanteling

Table 8: Dispencer general data (Standart values)

System	Unit	C 2610
Versiom		Rechts/ Links
Dispensing speed	m/min	3.0-15
Min. label width	mm	10
Max. width of the paperweb	mm	95
Min. label length	mm	10
Min. label length at max. dispensing speed	mm	20
Stop accuracy	mm	@ 15 m/ min ± 1mm
Minimal gap for optical scanner	mm	2
Max. diameter of paperroll	mm	250
Max. weight of paperroll	kg	10
Noise figure	dBA	< 70

Table 9: Traction unit

System	C2600
Driver	2-Phase steppermotor 200 steps
Motor voltage	32 V
Max. phase current	4.0 A
Type protection	IP40
Ambient temperature	+5-40 °C
Ambient humidity	15-90%, non condensing
Noise figure	< 70 dBA @ 1 m distance

Table 10: Weight

System	C2610
Weight	12 kg

Table 11: Midi-unwinder

Diameter of the roll core	42 mm
Max. outside diameter of roll	250 mm
Max. weight of roll	10 kg
Spring dancer with automatic brake	

Table 12: Adapter

System	Right/Left
Adapter angle	$\pm 90^\circ$, with adjustable snap-in locking
Ambient temperature	+5-40°C
Ambient humidity	15-90% non condensing

Table 13: Label scanner

Optical label scanner

15 Troubleshooting

15.1 Troubleshooting Collamat 2600

The troubleshooting will proceed along the paperpath. See following Figure 19

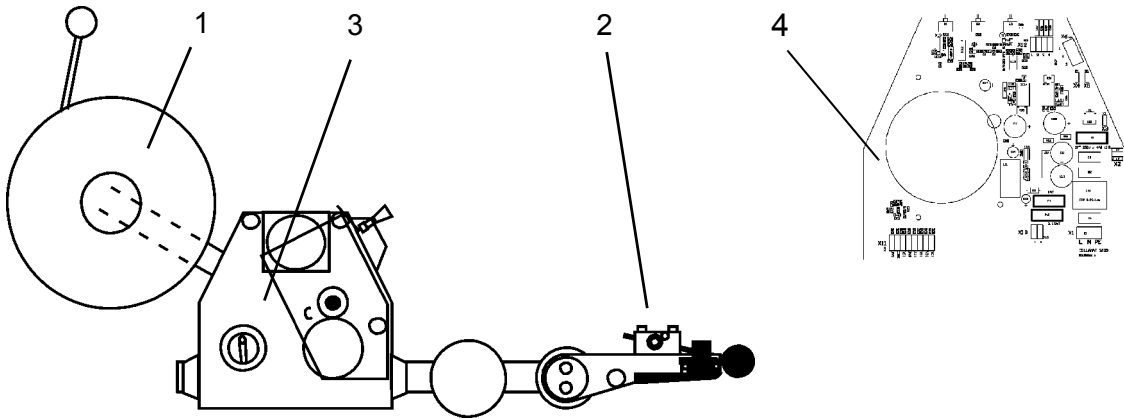

Figure 19: Troubleshooting

Table 14: Unwinder troubleshooting

SYMPTOMS	DIAGNOSIS	ACTION
Labels peel off at the dancer roll	Dancer roll diameter is too small	Change the standard roll against a roll with enlarged diameter
Dancer arm is bent and breaks	Dancer arm material is too weak or too thin (older Collamat)	Use new dancer arms (C2600/C6600/C7600)
Flange of the fixed disk breaks	Material defect, wrong type of aluminum	Replace flange against new series flange
Unwinder blocks	Disk touches the disk-brake.	Shift the disk on the unwindershaft away from the diskbrake
	Shaft is blocked	Lubricate the bearings on the shaft
	Diskbrake does not open	Readjust the diskbrake
The torsion spring comes off the knurled knob	Wrong kind of torsion spring	Exchange the torsion spring against an according torsion spring
The unwinder tends to fall off while side labeling	Paper roll too heavy	Mount a separate clamp to the module rail to stiffen the unwinder rail
Dancer roll gets shaky	Shaft screw is loose	Fix the screw (use perhaps Locktite)

Table 14: Unwinder troubleshooting

SYMPTOMS	DIAGNOSIS	ACTION
Dancer bearing gets shaky	Module rail is worn out by the dancer axle	Replace module rail and dancer axle
Paperweb falls off in side labeling applications	Missing side labeling kit	Mount the side labeling kit to the Collamat

Table 15: Adapter troubleshooting

SYMPTOMS	DIAGNOSIS	ACTION
Labels run through	Label sensor cable is broken	Replace label sensor cable
	IR transmitter cable is broken	Replace transmitter cable
	Label sticks below the label sensor	Remove the sensor and clean it properly
	IR light guide is blind	Replace IR light guide
	TCY-potentiometer is mis-adjusted	Readjust TCY
	Label scanner position not over the label	Place the scanner over the label transport path
Pressing roll is worn out	Roll is pressed too hard to the goods	Lift the labeler, reduce the adapter spring force
Pressing roll axle hangs/is bent down	Fixing hex nut is loose	Retighten the hex nut (apply Locktite)
	Pressing roll axle is bent or broken	replace the axl
Adapter flap gets shaky	Lever fixing screw is loose	Remove the flange holding the two knurled rolls and retighten the lever
Labels are not dispensed straight forward	Peeling bar is worn out	Replace the peeling bar
Labels form bubbles,	Labeling speed to fast	Reduce labeling speed
	Etikettierer ist schräg ausgerichte	Etikettierer neu ausrichten
Labels form wrinkles	Labeling speed to slow	Increase labeling speed
	Labeler is misaligned to product transport	Realign the labeler
Adapter tilts down while labeling	Backing paper not threaded between the adapter roll pair	Tread the paperweb correctly between the adapter roll pair

Table 15: Adapter troubleshooting

SYMPTOMS	DIAGNOSIS	ACTION
Paperweb breaks behind the peeling bar	Lateral paperguides hurt the paperweb	Enlarge the space between the paperguides
	Paperbrake set too hard	Reduce the braking force
	Peeling bar is too sharp	Use peeling bar with a bigger radius Add Teflon tape around the peeling bar
	Peeling bar touches the goodst	Lift the labeler/adapter away from the goods
	Paperweb is perforated	Use unperforated paperwebs or use a peeling bar with bigger radius

Table 16: troubleshooting traction unit

SYMPTOMS	DIAGNOSIS	ACTION
Pressure roller is shaky	Pressure roller shaft is broken	Replace pressure roller shaft
Traction roller turns in the wrong direction	Problems in the rewinder clutch	Release the breaking force of the rewinder
	Feltdisks are worn out	Replace the felt disks
	Parallel pin inside the rewinder shaft is blocked	Release the parallel pin clean and lubricate it
Motor is very hot	Kein Fehler	Dies ist normal für einen Schrittmotor
Motor makes high frequent noise	No fault	This is normal for a stepper motor
Traction roller is shaky while power on	Pin at the front flange of the tration roller is broken or worn out	Exchange pin or if necessary exchange the complete traction roller
	The toothed belt roll or the locking plate is broken	Exchange the toothed belt roll or exchange the locking plate and fix it tight

Table 16: troubleshooting traction unit

SYMPTOMS	DIAGNOSIS	ACTION
At higher labeling speed the motor stalls	Too much friction of the paperweb Clutching force of the rewinder is too high	Check the paperbrake Add Teflon tape to the peeling bar Reduce all friction of the paperweb where possible Check the unwinder dancer Release the breaking force of the rewinder or replace the felt disks
Paperweb breaks behind the paperbrake	Lateral paperguides hurt the paperweb Paperbrake set too hard	Enlarge the space between the paperguides Reduce the braking force

Table 17: troubleshooting control print

SYMPTOMS	DIAGNOSIS	ACTION
Motor is dead, power switch is not illuminated	No mains connected to trafo	Check for correct main connection Check main fuse F1 Check internal main switch wiring
Motor is dead, power switch is illuminated	Motordriver probably not working	Check motordriver fuse F10 Check for undervoltage Check for motordriver overheat Check on motorwires for short connection Check trafo wiring
Motor turning direction is wrong	Wrong Motor wiring	Reconnect motor wires according to the Technical Handbook
Motor makes noise and shakes. It does not turn correctly	Faulty motor driver chip Missing connection of one motor wire	Replace the board Connect motor wires according to the Technical Handbook

Table 17: troubleshooting control print

SYMPTOMS	DIAGNOSIS	ACTION
The potentiometers are broken	Transportation damage	Use the original transport box
The primary fuse often blows	The mains impedance is too low	Use an extended power cord

Please make a copy of this list before using it.

Table 18: Trouble shooting checklist

Machine type:		Ser.No. Dispenser board:	Ser.No. Labeler:
Environment	Mains voltage:	Frequency Hz:	Temperature °C:
	Humidity %:	Interference level (Burst):	Interference level (Static):
Labels	Width:	Length:	Gap:
	Thickness:	Transparency:	Material:
Paperweb	Width:	Thickness:	Transparency:
Goods	Kind:	Material:	Shape:
	Length:	Width:	Height:
	Speed m/min:	Length in sense of transport:	Distance between goods:
Labeler	Speed m/min:	Pieces / min:	Measuring:
Settings	Predispensing mm:	Position mm:	TCY value:
		Label length:	
Special:			
Machine environment	Conveyor:	Feeder:	Taker:
	Other machines around:		
Scening	Mains cables:	Sensor cables:	
ESD-Phenomena	Description::		
Description of the malfunctions:	Accumulation: continuous: periodical: Seconds intermittent:		
Date / ev. date and time of the last disturbances:			
Remarks:			
Disturbance registered by Name:			Date:

Die in diesem Handbuch enthaltenen Informationen entsprechen dem Stand zum Zeitpunkt der Veröffentlichung.

Technische Änderungen bleiben vorbehalten.

Revision History:

```
RCS file: /data/cvsreps/logobject/Collamat/DVP/Collamat2600/Documentation/
Technical_Handbook_En.fm,v
Working file: Technical_Handbook_En.fm
head: 1.3
branch:
locks: strict
access list:
symbolic names:
keyword substitution: b
total revisions: 3;  selected revisions: 1
description:
-----
revision 1.3
date: 2004/10/22 12:22:31;  author: vestli;  state: Approved;  lines: +812 -817
First Release
=====
```